

Ø.50 (4 PLACES)

8008256
FILTER / SILENCER

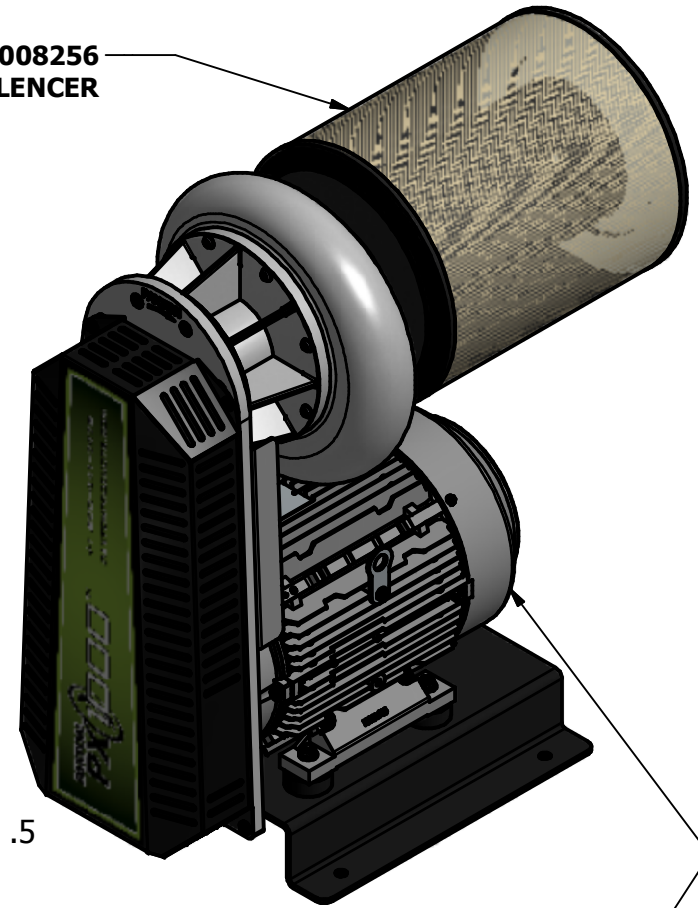

Motor:
GR3-AL-TF-215TC-2-B-D-10

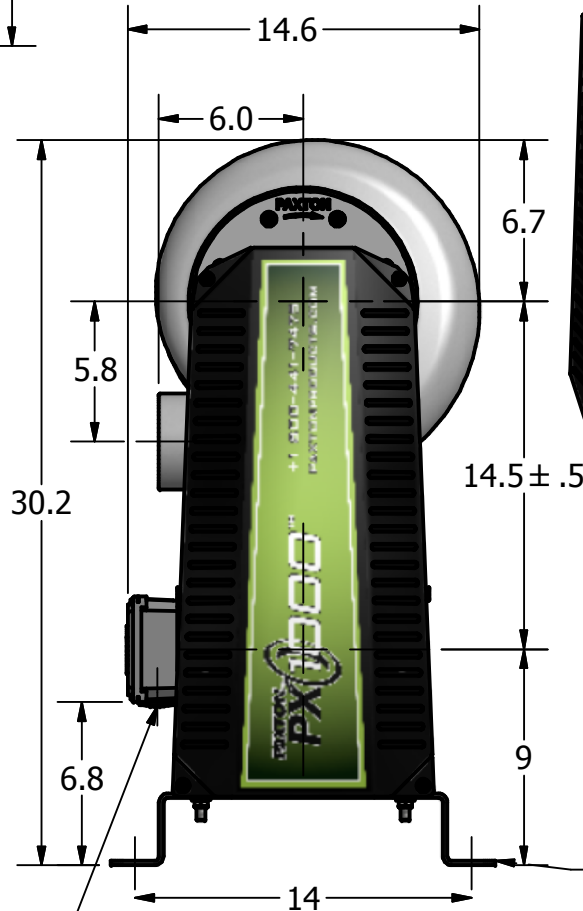

8005330-PX15,
MOUNTING BASE

1" NPT
ELECTRICAL
CONNECTION

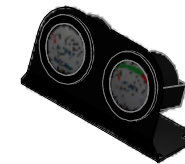

8008468, Gauge Kit
Blower Output Pressure (0-100" W/C)
Filter Pressure Drop (0-10" W/C)
With tubing and fittings

FOR REPLACEMENT PARTS INFORMATION OR EXACT C-C DIMENSION,
PLEASE SEE THE SPECIFIC "PARTS DIAGRAM" FOR YOUR BLOWER.

TYPICAL WT = 210 lbs

THIS DOCUMENT IS THE PROPERTY
OF PAXTON PRODUCTS AND IS
FURNISHED ON THE CONDITION
THAT IT IS TO BE USED ONLY BY
PAXTON CUSTOMERS FOR
INTEGRATING PAXTON
EQUIPMENT. THIS DOCUMENT
MAY BE USED BY CUSTOMERS TO
CREATE THEIR OWN EQUIPMENT
DOCUMENTATION. OTHERWISE
THIS DOCUMENT IS NOT TO BE
USED IN ANY SHAPE OR FORM TO
CREATE DOCUMENTS, PARTS, OR
EQUIPMENT.



10125 Carver Road Phone: (800) 441-7475
Cincinnati, OH 45242 (513) 891-7474
www.paxtonproducts.com

PX-1000 Blower Drawing
10Hp, 215TC, View B-G

DATE
2/29/2016

INVENTOR DWG No.
OA-PX1000-VIEW B-G